

Walter Grooving

One, two, or four cutting edges to maximize productivity

SEATTLE 1700 136th Place N.E. Bellevue, WA 98005 Tel: (425) 372-2000 Fax: (425) 372-2001 Toll Free: (800) 562-8375	PORTLAND 12820 S.E. Hwy 212 Clackamas, OR 97015 Tel: (503) 212-5353 Fax: (503) 212-5354 Toll Free: (800) 922-1263	SPOKANE 10925 E. Montgomery, Unit A Spokane, WA 99206 Tel: (509) 891-4047 Fax: (509) 891-4051 Toll Free: (800) 854-7601
--	---	---

Free grooving tool

SEE DETAILS BELOW

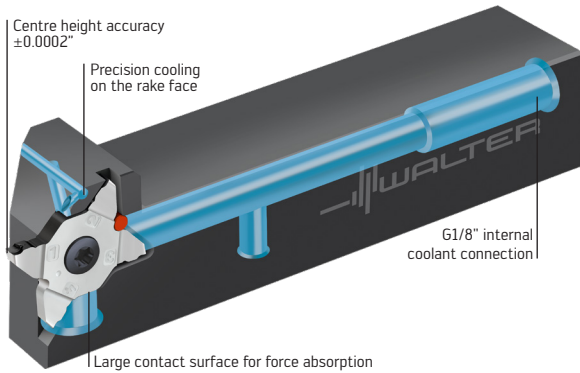

MX Tangential arrangement enables outstanding flatness and surface quality

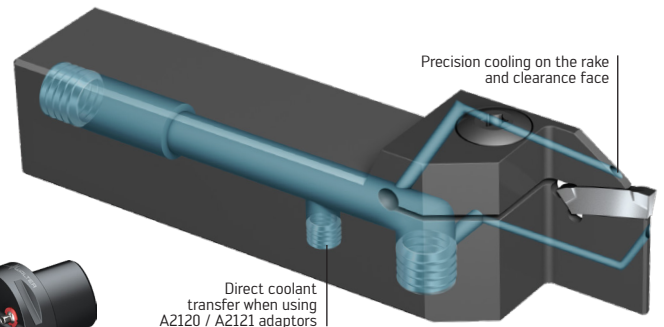

Universal "go to" system for grooving, groove-turning, and parting off **GX**

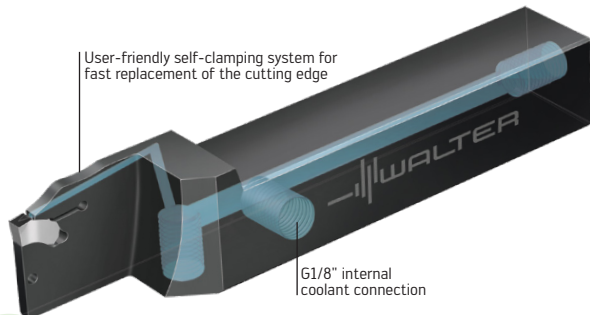

SX Deep grooving and parting off with internal coolant

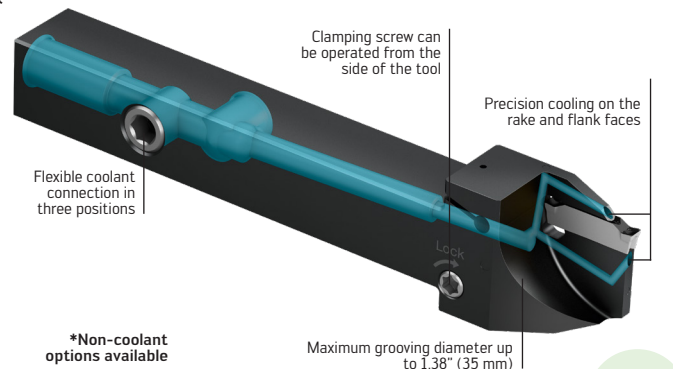

Patented parting-off system, ideal for Swiss machining **DX**

Promotion Details

Purchase qualifying number of inserts (see page 2) in the corresponding system and receive the tool holder free! *For modular tools, purchase 1 box per tool body and 1 box per module. Promotion dates: October 1st thru December 31st, 2020

Use promo code **GROOVINGQ4**

The best for all grooving operations

MX system

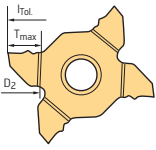
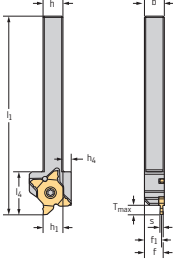
Insert	Holder	s in	T _{max} in	b in	h = h ₁ in	l ₁ in
		MX22-2E318N02-CF5 WSM23S 0.125	-	-	-	-
Holder						
G3011-1212R-MX22-2		-	0.236	0.472	0.472	4.724
G3011.08R-MX22-2-P		-	0.236	0.5	0.5	4.724

Promotion Details*

- Buy (5) MX inserts, get one non-thru coolant holder for free
- Buy (10) MX inserts, get one thru coolant (-P) holder for free
- Buy (10) MX inserts, get one monoblock Capto holder for free

*offer shown for example only, see full promotion details in Q4 customer presentation or contact your local Walter representative.

SX system

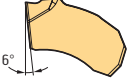
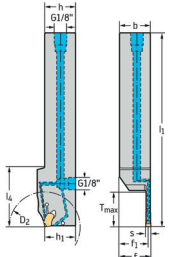
Insert	Holder	s in	T _{max} in	b in	h = h ₁ in	l ₁ in
		SX-3E300N02-CF5 WSM33S 0.118	-	-	-	-
Holder						
G2012.16R-3T33SX		-	1.299	1.0	1.0	5.906
G2012.16R-3T33SX-P		-	1.299	1.0	1.0	5.906

Promotion Details*

- Buy (10) SX inserts, get one non-thru coolant holder for free
- Buy (20) SX inserts, get one thru coolant (-P) holder for free

*offer shown for example only, see full promotion details in Q4 customer presentation or contact your local Walter representative.

*For modular tools, purchase 1 box per tool body and 1 box per module.

GX system

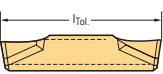
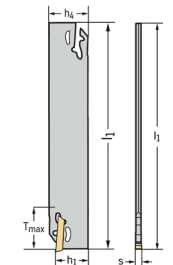
Insert	Holder	s in	T _{max} in	b in	h = h ₁ in	l ₁ in
		GX24-3E400N02-CF5 WSM33S 0.157	-	-	-	-
Holder						
G1011.12R-3T21GX24		-	0.827	0.75	0.75	5.906
G1011.12R-3T21GX24-P		-	0.827	0.75	0.75	5.906

Promotion Details*

- Buy (10) GX inserts, get one non-thru coolant holder for free
- Buy (20) GX inserts, get one thru coolant (-P) holder for free

*offer shown for example only, see full promotion details in Q4 customer presentation or contact your local Walter representative.

*For modular tools, purchase 1 box per tool body and 1 box per module.

DX system

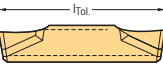
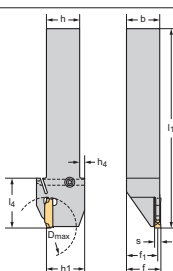
Insert	Holder	s in	D _{max} in	b in	h = h ₁ in	l ₁ in
		DX18-2E200R7-CF5 WSM23S 0.079	-	-	-	-
Holder						
G4014.08R-1.5T12DX18		-	0.984	0.5	0.5	4.331
G4014.08R-2T12DX18-P		-	0.984	0.5	0.5	4.331

Promotion Details*

- Buy (10) DX inserts, get one non-thru coolant holder for free
- Buy (20) DX inserts, get one thru coolant (-P) holder for free

*offer shown for example only, see full promotion details in Q4 customer presentation or contact your local Walter representative.

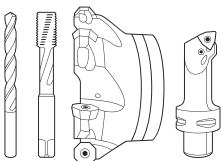

SEATTLE
1700 136th Place N.E.
Bellevue, WA 98005
Tel: (425) 372-2000
Fax: (425) 372-2001
Toll Free: (800) 562-8375

PORTLAND
12820 S.E. Hwy 212
Clackamas, OR 97015
Tel: (503) 212-5353
Fax: (503) 212-5354
Toll Free: (800) 922-1263

SPOKANE
10925 E. Montgomery, Unit A
Spokane, WA 99206
Tel: (509) 891-4047
Fax: (509) 891-4051
Toll Free: (800) 854-7601

walter-tools.com/us